

PHYSICS

YEAR 12

STAGE 3

2012

Name: _____

Teacher (circle): MASSANG / COOPER

TIME ALLOWED FOR THIS PAPER

Reading time before commencing work: Ten minutes

Working time for the paper: Three hours

MATERIALS REQUIRED/RECOMMENDED FOR THIS PAPER

To be provided by the supervisor:

- This Question/Answer Booklet; Formula and Constants sheet

To be provided by the candidate:

- Standard items: pens, pencils, eraser or correction fluid, ruler, highlighter.
- Special items: Calculators satisfying the conditions set by the Curriculum Council for this subject.

IMPORTANT NOTE TO CANDIDATES

No other items may be taken into the examination room. It is **your** responsibility to ensure that you do not have any unauthorised notes or other items of a non-personal nature in the examination room. If you have any unauthorised material with you, hand it to the supervisor **before** reading any further.

All calculations are to be set out in detail. Marks may be awarded for correct equations and clear setting out, even if you cannot complete the calculation. Express **numerical answers** to three (3) significant figures and include units where appropriate. Express **estimates** to two (2) significant figures, and state any assumptions clearly.

Structure of this paper

Section	Number of questions available	Number of questions to be answered	Suggested working time (minutes)	Marks available	Percentage of exam
Section One: Short answer	13	13	50	54	30
Section Two: Extended answer	8	8	90	90	50
Section Three: Comprehension and data analysis	2	2	40	36	20
Total				180	100

Instructions to candidates

- The rules for the conduct of Western Australian external examinations are detailed in the *Year 12 Information Handbook 2012*. Sitting this examination implies that you agree to abide by these rules.
- Write answers in this Question/Answer Booklet.
- You must be careful to confine your responses to the specific questions asked and follow any instructions that are specific to a particular question.
- Working or reasoning should be clearly shown when calculating or estimating answers. It is suggested that answers to calculations are given to 3 significant figures except when you are required to estimate. For estimation questions an appropriate number of significant figures must be stated.
- Spare pages are included at the end of this booklet. They can be used for planning your responses and/or as additional space if required to continue an answer.
 - Planning: If you use the spare pages for planning, indicate this clearly.
 - Continuing an answer: If you need to use the space to continue an answer, indicate in the original answer space where the answer is continued, i.e. give the page number. Refer to the question(s) where you are continuing your work.

Section One: Short response**30% (54 Marks)**

This section has **13** questions. Answer **all** questions. Write your answers in the space provided. Suggested working time for this section is 50 minutes.

Question 1

When sound waves travelling through water meet a boundary with air there will be some reflection and some refraction. Complete the diagram by showing how the wavefronts behave as they continue from the boundary. You should draw four wavefronts for each case. (The dotted line is a 'normal' which is a geometrical reference line at 90° to the boundary)

(4)

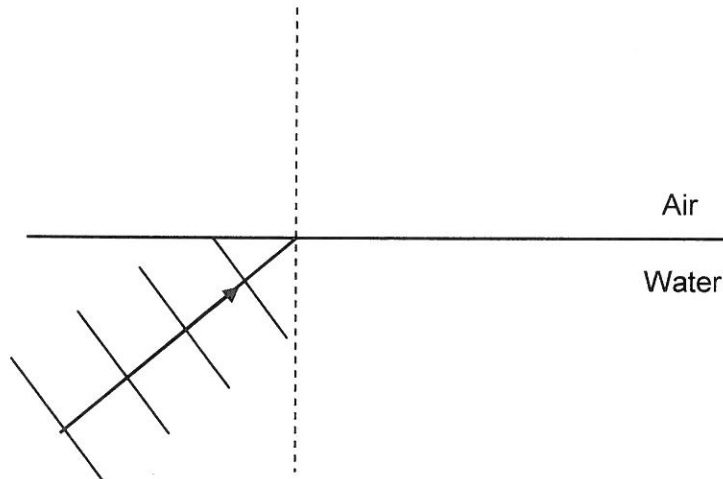
**Question 2**

When demonstrating the photoelectric effect a beam of light is shone onto a clean metal surface. If the light is above a certain threshold frequency it causes electrons to be ejected from the surface. Explain if this indicates that light is behaving as a particle or a wave.

(3)

Question 3

A student is investigating the physics of the hammer throw event at the London Olympics. A hammer of mass 7.30 kg is describing uniform circular motion at a constant height. The length of the hammer is 1.21 m and the wire makes an angle of 77.2° with the vertical. Calculate the time taken for the hammer to make one revolution.

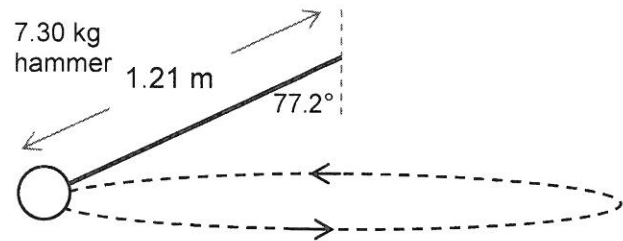

(5)

Question 4

A jet is flying directly over the magnetic pole in the Northern geographical hemisphere. The jet is flying at 858 km h^{-1} , it has a wingspan of 15.0 m and the Earth's magnetic flux density at this location is $57.8 \mu\text{T}$.

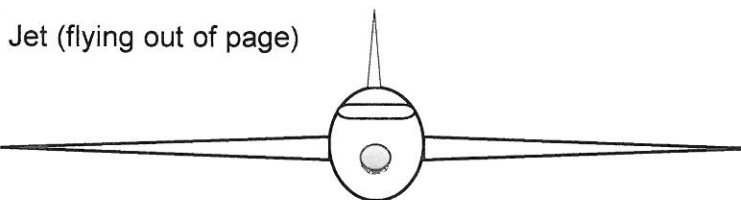

Magnetic Pole Northern Hemisphere

- Draw the Earth's magnetic field at this location by using 5 lines. (1)
- Indicate on the diagram where electrons will build up on the wingspan. (1)

SEE NEXT PAGE

c) Calculate the emf induced across the wingspan.

(2)

Question 5

A spacecraft moving at 95% of the speed of light passes the Earth on a journey to the star Lalande 21185 a distance of 8.29 light years.

a) In the frame of reference of the spacecraft what time and spatial measurements of the journey are different compared to those measured by an Earth based observer?

(2)

b) In the frame of reference of the Earth what time and spatial measurements of the journey are different compared to those measured by an observer on the spacecraft?

(2)

c) Is it possible for the spacecraft to travel at the speed of light in the frame of reference of the spacecraft? Explain briefly.

(1)

Question 6

There are six flavours of quarks (normal matter versions). These are detailed in the table.

Quark	Charge
Up (u)	$+\frac{2}{3}e$
Down (d)	$-\frac{1}{3}e$
Charmed (c)	$+\frac{2}{3}e$
Strange (s)	$-\frac{1}{3}e$
Top (t)	$+\frac{2}{3}e$
Bottom (b)	$-\frac{1}{3}e$

- a) Determine the charge of the following particles that are made from quarks:

Bottom Xi prime (**dsb**) _____

Kaon-plus (**u \bar{s}**) _____

(2)

- b) Give an example from your studies of when a neutrino could come into existence.

(2)

Question 7

Oxygen ions (O^{2-}) are injected into a vacuum chamber that contains a uniform magnetic field. For the cross section shown the magnetic flux is $2.88 \times 10^{-4} \text{ Wb}$ in an area 30.0 cm by 20.0 cm . The direction of the magnetic field is indicated and the ions enter at a speed of $2.76 \times 10^4 \text{ m s}^{-1}$.

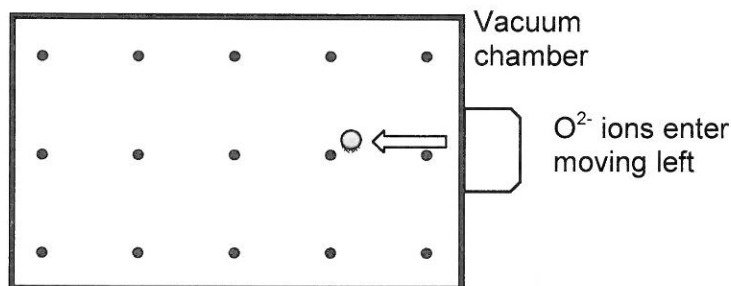

- a) In which direction will the ions be deflected? (Circle the correct response)

up the page down the page into the page out of the page

(1)

- b) Calculate the magnitude of force experienced by each ion.

(3)

Question 8

A rigid wooden plank of mass 2.5 kg is attached to a wall by a pivot and is supported by a rope in tension. A 3.5 kg bowling ball is suspended from the plank. The diagram is to scale. **Estimate** the tension in the rope. Express your answer to an appropriate number of significant figures.

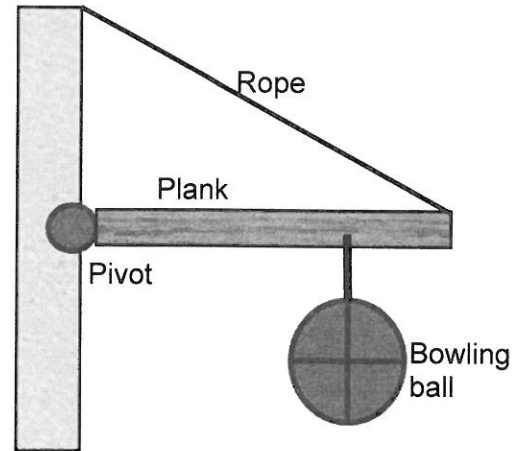

(4)

Question 9

A rigid boom of mass m is free to rotate about a frictionless pivot P . The boom is held in static equilibrium by a rope that is in tension. The boom is held in two different positions where the tension in position A is T_A and the tension in position B is T_B . The positions are shown in the diagram below.

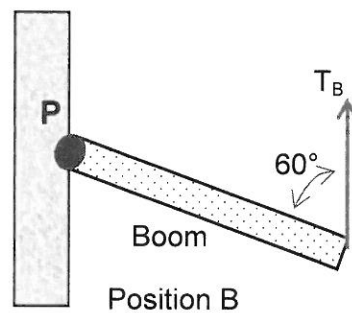
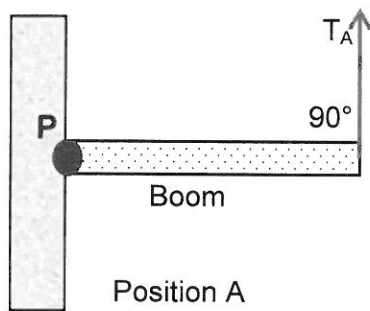

a) When comparing the magnitude of tension in each position, circle the best response:

- $T_A = T_B$
 $T_A > T_B$
 $T_A < T_B$
 Insufficient information for a response

(1)

b) Clearly explain your choice.

(3)

Question 10

In the WACE Physics course we assume that the flux linkage between the primary and secondary windings of a transformer is always 100% efficient. However we recognise that the transformer itself may not be 100% efficient.

a) Describe two sources of inefficiency in a transformer.

(2)

b) Describe how these inefficiencies affect the electrical characteristics of a transformer.

(1)

c) Explain how the design of a transformer can be modified to minimise the effects of these inefficiencies.

(2)

Question 11

(4)

a) The diagram at right shows a permanent magnet and a wire carrying current.



i. Sketch 6 lines to indicate the field of the magnet.



ii. Indicate on the diagram the direction of magnetic force acting on the wire

b) The diagram at right shows the cross section of a powered solenoid. The magnetic polarity at each end of the solenoid is shown.

i. Shown on the diagram, the direction of current that will establish this field.

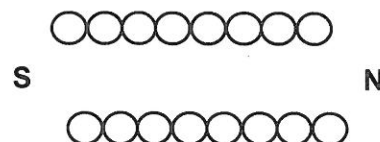

ii. Sketch 3 magnetic field lines within the solenoid core.

Question 12

A person is sitting on a swing that is moving through the arc of a circle. It has reached the lowest point and is moving at maximum speed. Explain with reference to a vector diagram how the person's apparent weight is different compared to being at rest on the swing.

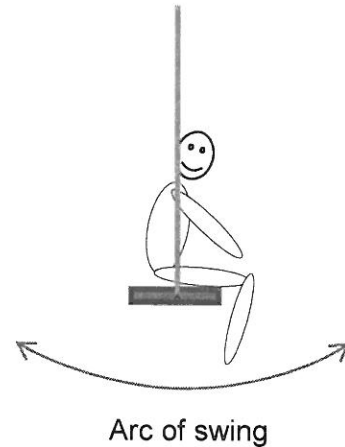

(4)

Question 13

The Steady State Theory (also called The Infinite Universe Theory) was a model developed by the respected astronomer Fred Hoyle and others in 1948. It proposed that the universe had no beginning or end over infinite time. Fred Hoyle is reported to have used the phrase 'Big Bang' as a derogatory term when referring to an alternative theory that is nowadays the most widely accepted.

Describe two pieces of observational evidence that support the Big Bang Theory.

(4)

NAME: _____ TEACHER(circle): MASSANG / COOPER

Section Two: Problem-solving

50% (90 Marks)

This section has **eight (8)** questions. You must answer **all** questions. Write your answers in the space provided. Suggested working time for this section is 90 minutes.

Question 14 (13 marks)

The diagram shows the side view of a DC electric motor. A square coil is placed flat in the uniform magnetic field between the North and South magnetic poles. Current direction in the coil is shown on the sides adjacent to the magnetic poles. The commutator and carbon brushes are also shown.

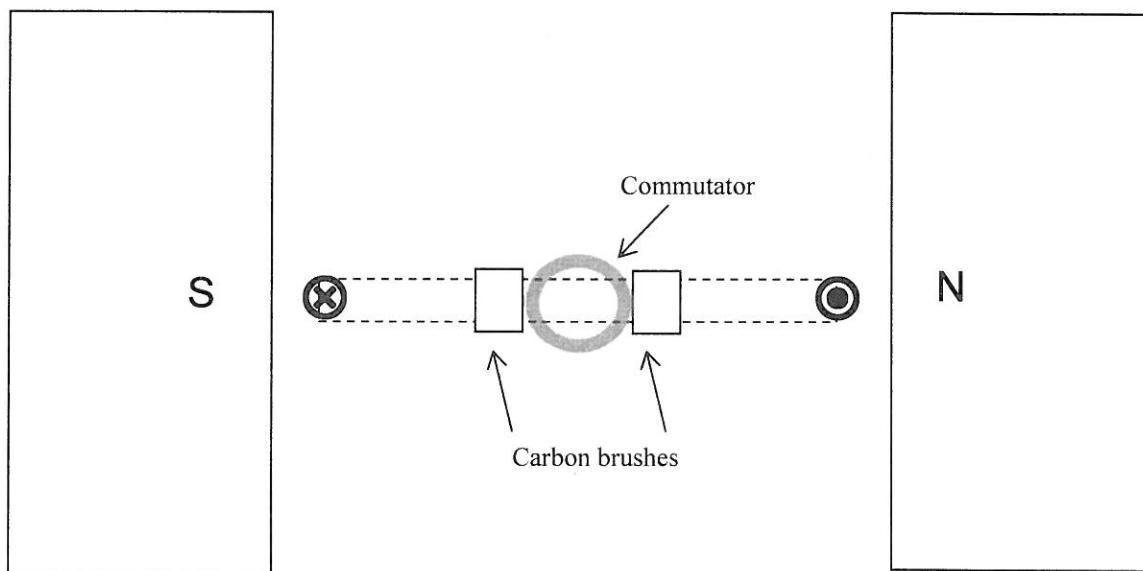

- In which direction will the coil turn from this start position? (1)
- On the diagram sketch and label the location/s of insulator materials on the commutator at this start position. (1)
- Explain the function of the brush and commutator arrangement. (2)
- Using the symbols \odot and \otimes sketch on the above diagram the location of the coil after 60° of rotation from this start position. Put arrows on your symbols to indicate the direction of magnetic force acting on them. (2)

- e. At this new position after 60° of rotation from the start position; state the torque value of the motor as a percentage of maximum torque.

(2)

- f. A single 90.0 mm length of wire adjacent to a magnetic pole experiences a 0.0240 N force when a current of 6.20 A is present. Calculate the magnetic flux density between the poles.

(2)

- g. The motor is later modified to have two sets of evenly spaced coils and a commutator with four segments. On the axes below, sketch the shape of the torque output curve for one revolution from the start position shown.

(3)

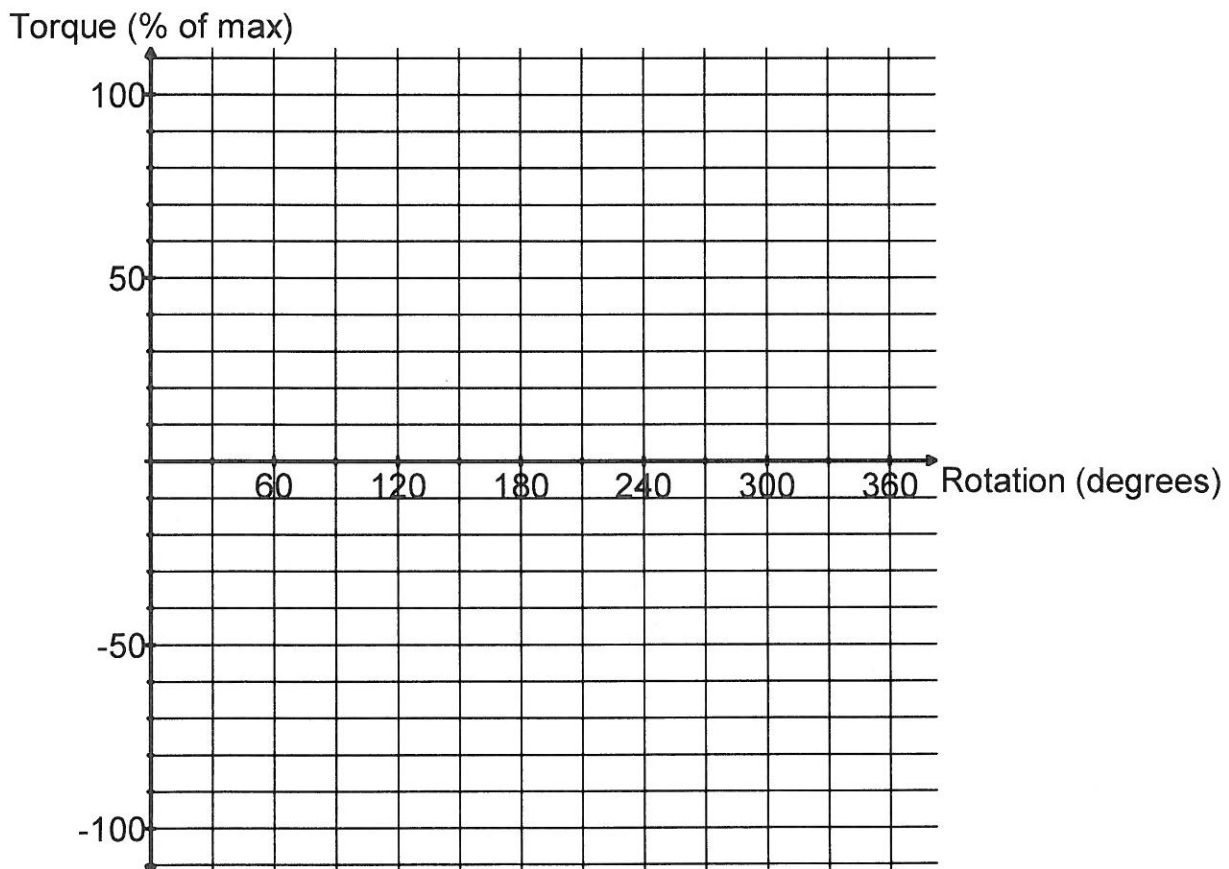

Question 15 (13 marks)

A recording studio builds a simple didgeridoo which is a wind instrument closed at one end. The effective length of the didgeridoo is 135 cm and is fixed.

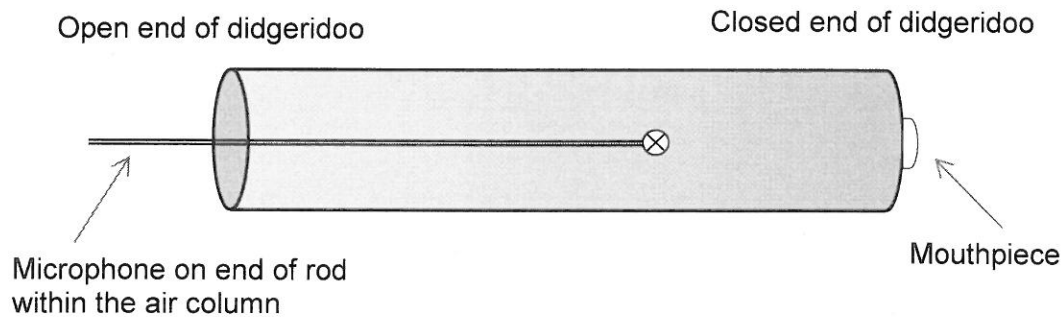

- a) The didgeridoo has a fundamental frequency of 64.0 Hz. Calculate the speed of sound of air in the studio. (3)

- b) Explain how a musician can play notes of a higher frequency on this fixed length instrument. (2)

- c) The musician is unable to produce a sound of frequency 128 Hz on this didgeridoo. Explain why this is not possible. (2)

When the didgeridoo is playing a note of frequency 320 Hz, a sound technician slides a small microphone into the tube without disrupting the sound. As he does, he notices the sound volume varies between loud and soft.

d) Explain why there are loud and soft spots within the instrument.

(2)

For a given note played on a musical instrument, the dominant frequency heard is called the fundamental frequency or the first harmonic. Harmonic frequencies above the fundamental frequency, that are present, are known as overtones. Harmonics above the fundamental frequency are known as the first overtone, the second overtone etc.

e) The studio has a simple stringed instrument in which a steel string in tension can oscillate between two fixed bridges. On the diagram below sketch the wave envelope of the second overtone.

(1)



f) When the didgeridoo is sounding a note of 64.0 Hz, sound waves travel through a small gap in a partially open window to the outside where reflections are negligible. A microphone placed to the side of the gap can still detect these sound waves. This is shown in the following diagram.

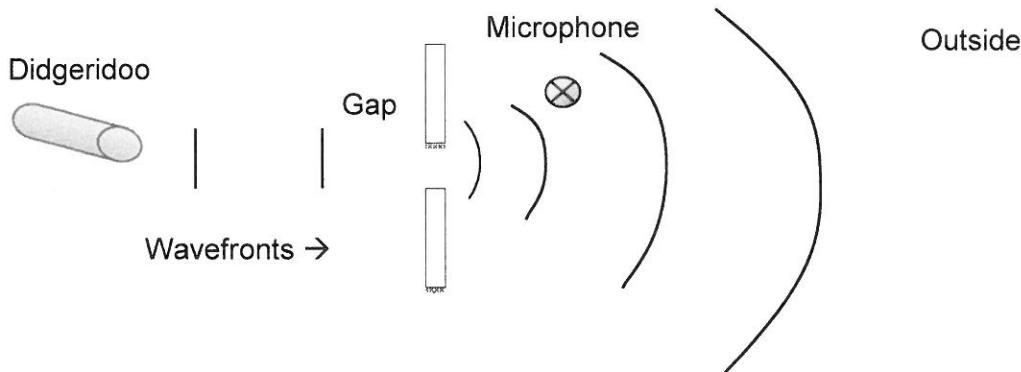

i. Explain the wave phenomenon that causes the didgeridoo sound to be detected by the microphone.

(2)

ii. Show on the diagram how wavefronts from the stringed instrument sounding at 320 Hz will reach the window and continue through the air gap. You must show relative wavefront dimensions approximately to scale originating from the same location as the didgeridoo.

(1)

Question 16 (12 marks)

A physics student observes a stone of mass $3.50 \times 10^2 \text{ g}$ being catapulted from the top of a cliff. The launch position at the top of the cliff is 15.0 m above ground level and it takes the stone a time of 5.00 seconds to reach the ground. The stone lands 88.0 m in front of the launch position. You may ignore air resistance for the calculations.

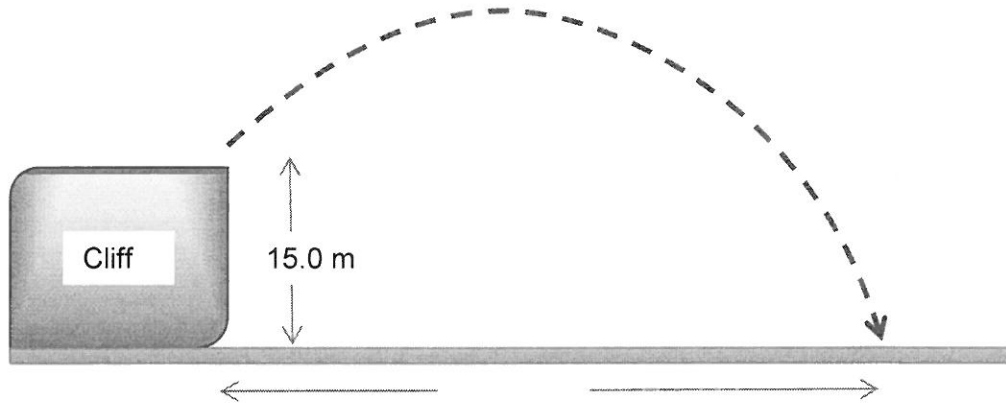

a) Calculate the vertical component of the velocity when the stone is launched.

(3)

b) Considering the kinetic energy of the stone along its flight path. Circle the best response for the following statement. The kinetic energy of the stone at maximum height is:

Maximum 50% of maximum Zero Minimum Equal to all other positions

(1)

c) Calculate the initial velocity of the stone, referring to the angle of elevation above the horizontal for direction.

(4)

d) Calculate the kinetic energy of the 3.50×10^2 g stone just before it hits the ground.

(4)

Question 17 (13 marks)

The diagram shows the coil PQRS of an AC generator placed between magnetic poles.

- The uniform magnetic field of flux density 0.0386 T is indicated.
- The dimensions of the coil are: PQ = SR = 7.00 cm and PS = QR = 5.00 cm
- The coil rotates about the axle as indicated when a torque is applied to the pulley.
- The coil has 4.00×10^2 turns of wire and is rotated at 7.50×10^2 revolutions per minute (rpm).

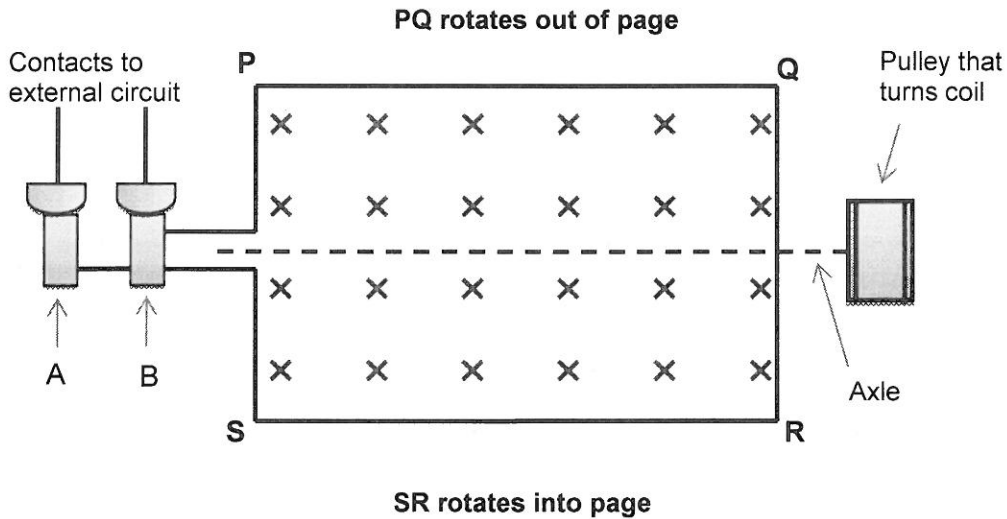

- a) Identify components A and B shown on the diagram, explain their function and explain why they are used rather than a commutator.

(3)

- b) Mark on the diagram the direction of current along PQ and SR as the coil rotates from the position shown and explain briefly how you arrived at your answer.

(2)

- c) Calculate the magnitude of the average induced emf from the AC generator by considering one quarter of a rotation from the position shown. (4)

- d) On the axes shown below, sketch the shape of the emf output for this generator as it rotates one full turn from the initial position shown. Put in a suitable numerical time scale on the time axis and label your curve '750 rpm'. (2)

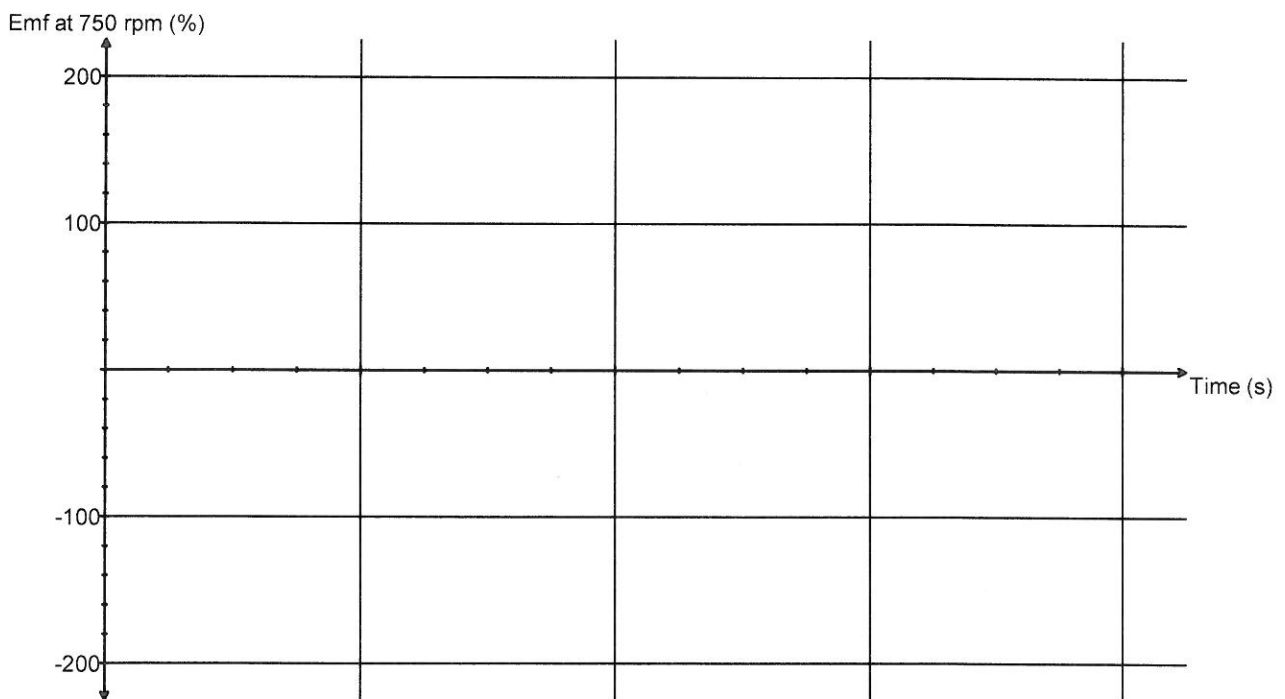

- e) Sketch a second shape of the emf output for a rate of rotation of 1500 rpm and label this curve '1500 rpm'. (2)

Question 18 (13 marks)

The energy level diagram below is for an atom that can fluoresce.

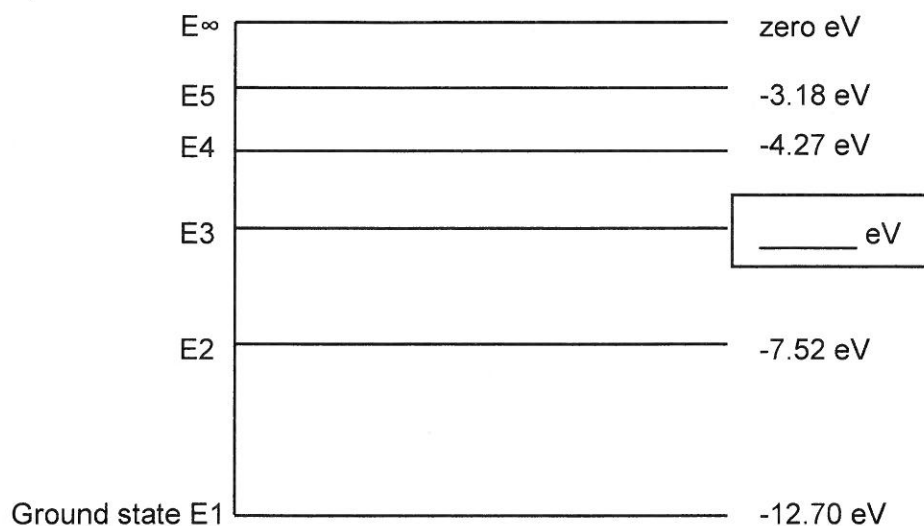

- a) The atom is bombarded by 4 photons with energies detailed below. Circle all of the photon energies that could be absorbed by the atom whilst in its ground state.

5.08 eV

5.18 eV

8.43 eV

13.0 eV

(1)

- b) Whilst in the ground state the atom absorbs a photon of wavelength 171.23 nm which excites the atomic electron to E3. Calculate the energy level of E3 and write it in the box on the diagram and also illustrate the transition on the diagram. Label the transition '171.23 nm'.

(4)

- c) Which part of the electromagnetic spectrum does the 171.23 nm photon belong to?

(1)

d) For the energy levels shown on the diagram below which transition will result in line emission of the longest wavelength? Illustrate this transition on the diagram and label it ' λ_{\max} ' (1)

e) Explain how a line absorption spectrum could be formed by a collection of these atoms. (3)

f) Explain the process of fluorescence. You may use the energy level diagram below to aid your response.

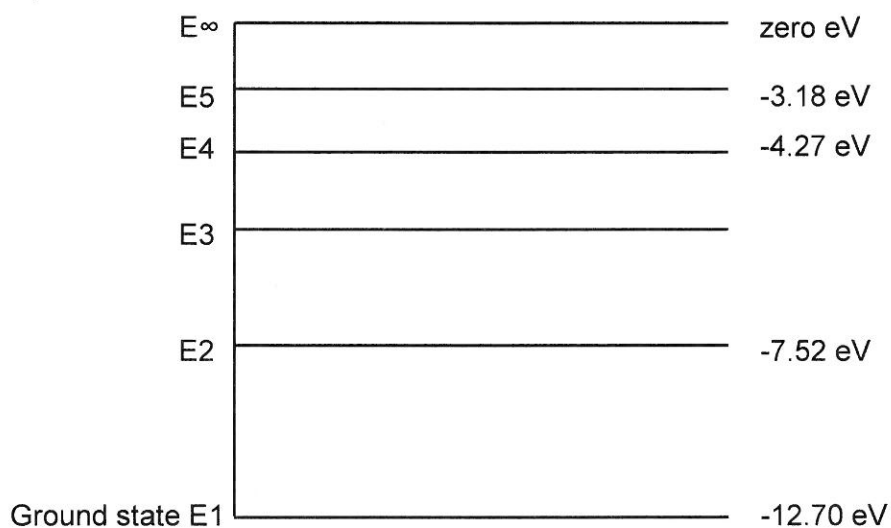

(3)

Question 19 (13 marks)

The orbit of Venus lies between the Earth's orbit and the Sun. The radius of Venus is 6.05×10^6 m. The Magellan spacecraft was launched by NASA in 1995 for the purpose of radar mapping Venus. At one stage Magellan was put into a circular orbit of Venus at an altitude of 346 km. It took Magellan 94.0 minutes to complete this orbit. Magellan had a mass of 1035 kg.

a) Calculate the centripetal acceleration of the Magellan satellite in this orbit.

(3)

b) Calculate the mass of the planet Venus using the satellite data provided.

(3)

- c) If the Magellan spacecraft was double the mass in this orbit explain how its orbital period would be affected. (2)

- d) There is a location between the Earth and the Sun where the net gravitational field strength due to the Earth and the Sun is zero. Calculate the distance from Earth to this location. (5)

Question 20 (7 marks)

An uncharged flake of metal is stripped of 9.57 million electrons and fed into the space between two horizontal plates set 35.0 mm apart. The plates are charged by a source of emf that establishes an electric field strength of $6.40 \times 10^4 \text{ N C}^{-1}$ in the space. The metal flake is seen to rise up in the space between the plates.

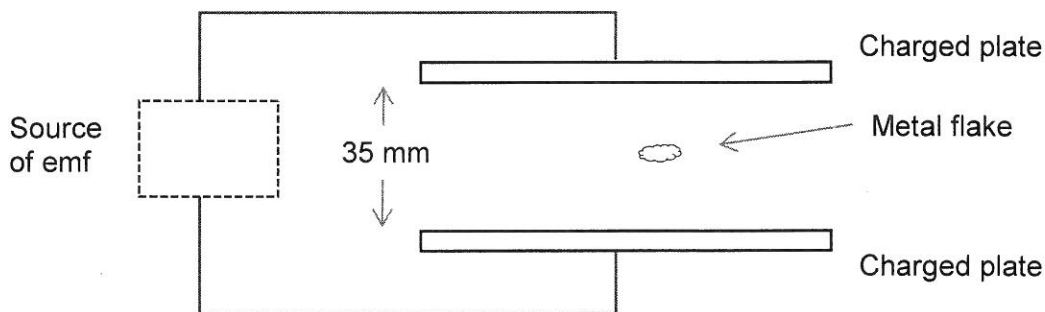

- a) Indicate on the diagram the polarity of the source of emf, the charge polarity on each plate and sketch at least five field lines for the uniform electric field. (2)

- b) Calculate the magnitude of the potential difference across the parallel plates (2)

- c) Calculate the magnitude of the electric force acting on the metal flake. (3)

Question 21 (6 marks)

NGC 2768 is a galaxy group that can be observed from the Hubble Space telescope. The line absorption spectrum of light passing through a metallic vapour in this galaxy shows one line with a wavelength of 742.540 nm. The same line in the spectrum measured on Earth is 740.400 nm.

- a. Calculate the recessional velocity of NGC 2768 using the following relationship:

(3)

$$\frac{\Delta\lambda}{\lambda_{rest}} = \frac{v}{c_0} \quad \text{where} \quad \Delta\lambda = \lambda_{shifted} - \lambda_{rest} \quad \text{and } v = \text{recessional velocity (m s}^{-1}\text{)}$$

- b. Using Hubble's law, calculate the distance in Mpc to galaxy NGC 2768 using the velocity you calculated. (If you could not solve for the velocity then use a value of $8.67 \times 10^5 \text{ m s}^{-1}$)

(2)

Hubble's law states that: $v = H_0 \cdot d$

$v = \text{recessional velocity (km s}^{-1}\text{)}$
 $d = \text{distance (Mpc)}$
 $H_0 = 74.0 \text{ km s}^{-1} \text{ Mpc}^{-1}$

- c. How many years has it taken light from this galaxy to reach Earth? (1 parsec = 3.26 light year)

(1)

NAME: _____ TEACHER (circle): MASSANG / COOPER

Section Three: Comprehension 20% (36 Marks)

This section contains **two (2)** questions. You must answer both questions. Write your answers in the space provided. Suggested working time for this section is 40 minutes.

Question 22 Using a mass spectrometer for a crime scene investigation. (18 marks)

Australian Federal Police have isolated an element found at a crime scene. They think the element may be sodium or potassium so have asked the forensic laboratory to run tests on the element to identify it. The laboratory is able to ionise the element to give it a single positive charge. They then accelerate the ions through a potential difference (V_d) and by use of a velocity filter are able to send ions that have reached their maximum kinetic energy into a mass spectrometer. When the ions enter the mass spectrometer they are acted on by a uniform magnetic field and follow a semi-circular path.

Technicians conduct a series of tests and measure the radius of circular motion for different values of potential difference used to accelerate the charged ions.

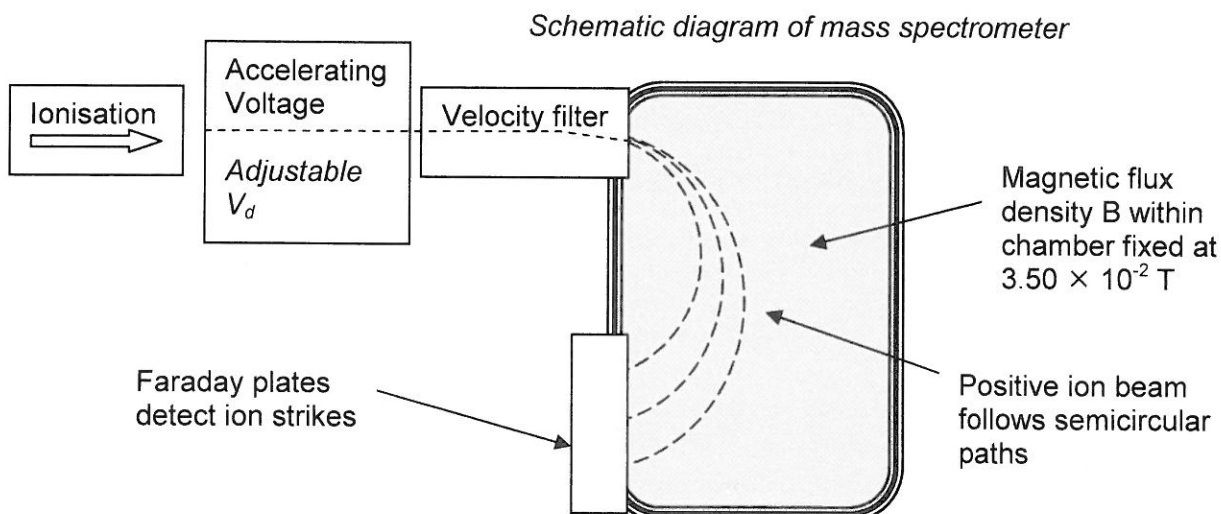

The table below shows the results obtained when the magnetic flux density B in the mass spectrometer was fixed at 3.50×10^{-2} T. Measurements of radius have been expressed with an uncertainty of $\pm 5\%$ and radius squared with an uncertainty $\pm 10\%$.

Potential difference V_d (volts)	Radius of circular path (metres)	Radius squared (metres squared)
200	0.270 ± 0.014	0.073 ± 0.007
400	0.370 ± 0.019	
600	0.490 ± 0.025	
800	0.530 ± 0.053	
1000	0.620 ± 0.027	
1200	0.670 ± 0.034	0.449 ± 0.045

Mass of a potassium K^+ ion = 6.49×10^{-26} kg

Mass of sodium Na^+ ion = 3.82×10^{-26} kg

It can be shown that the radius r of circular motion for an ion of mass m and charge q , entering the mass spectrometer at speed v and being deflected by a magnetic field of flux density B is as follows:

$$r = \frac{m \cdot v}{q \cdot B}$$

Answer the following questions

- a) Use the equation $r = \frac{m \cdot v}{q \cdot B}$ and other equations on the formulae and constant sheet that link the kinetic energy in (joules) attained by a mass of charge q (coulombs) in a potential difference V_d (volts) and derive the following expression:

(3)

$$r^2 = \frac{2 \cdot m}{q \cdot B^2} \cdot V_d$$

The equation follows the format $y = mx + c$ for values of r^2 plotted against V_d

- b) Complete the table by filling in the values of radius squared r^2 with the appropriate uncertainty range. Two values have been done for you.

(3)

- c) Plot the graph of r^2 (vertical axis) versus **Potential difference V_d** (horizontal axis) on the graph paper next to the table. Include error bars and a line of best fit.

(5)

If you need to make a second attempt, spare graph paper is at the end of this question. Indicate clearly if you have used the second graph and cancel the working on the first graph.

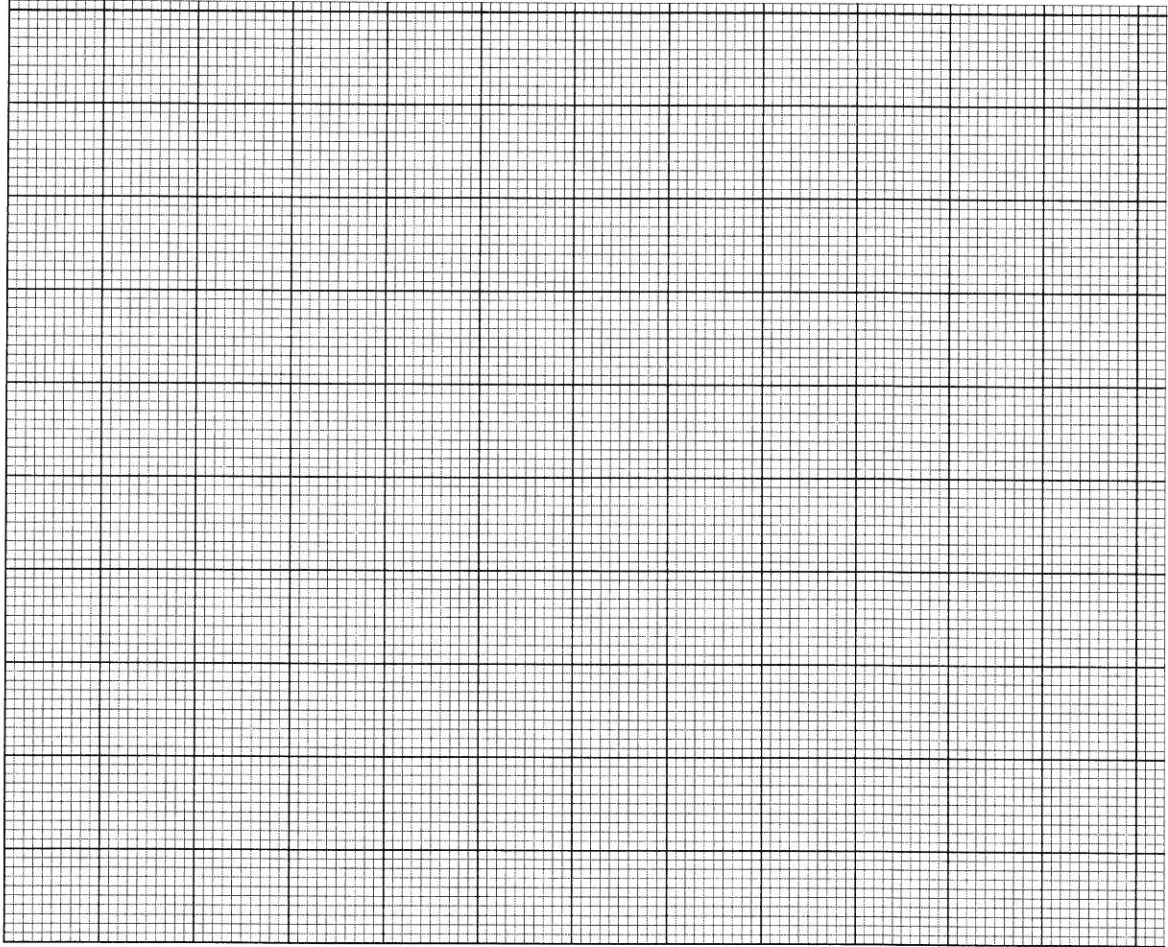

d) Calculate the gradient of your line of best fit from your graph showing all working. (3)

e) Use the value of the gradient that you obtained to calculate the mass of the charged ions. (If you could not obtain a gradient use the numerical value 4.00×10^{-4}) (3)

f) Based on the results you have calculated, what is the identity of the charged ion? (1)

Spare graph paper

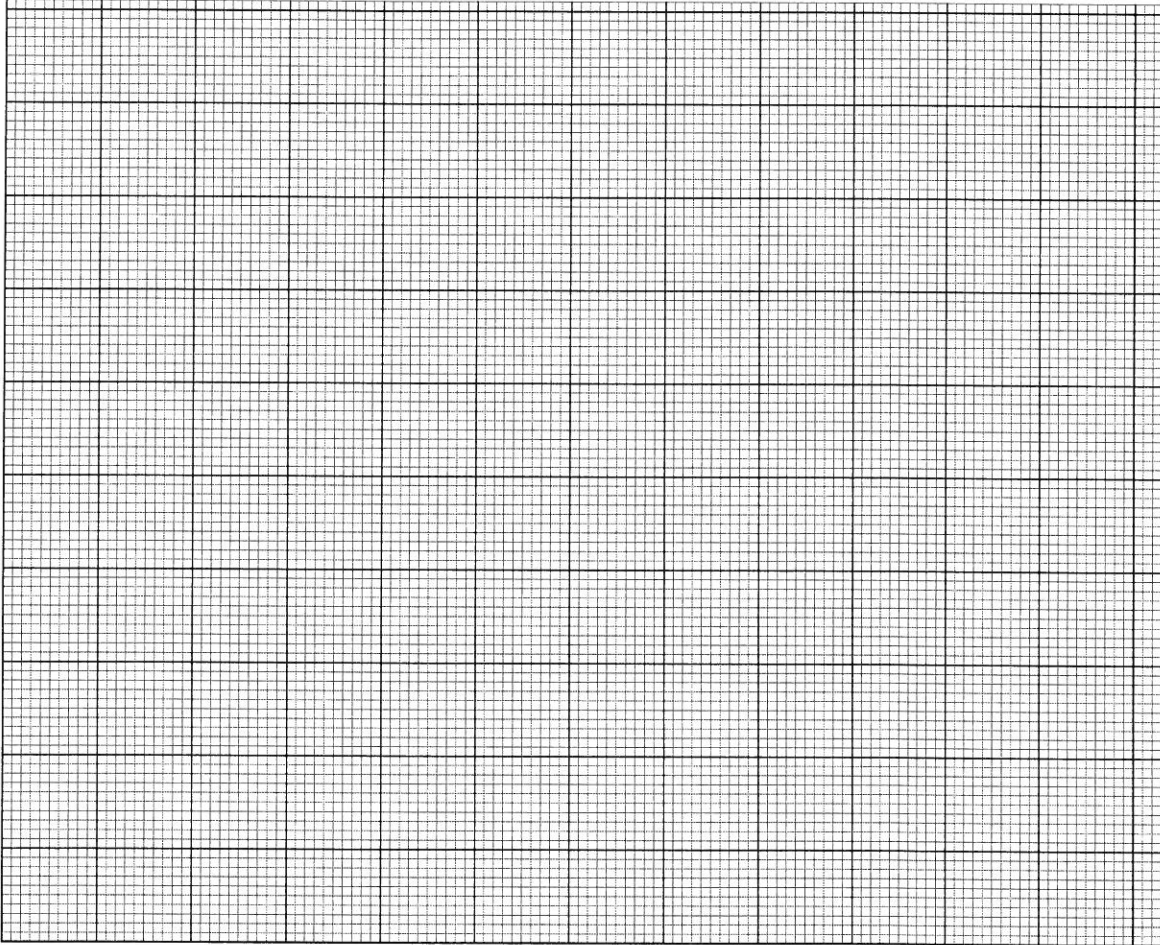

Question 23**Clocks****(18 marks)**

Our lives are governed by time. The concept of a day divided into 24 hours originated in ancient Egypt. The hour divided into 60 minutes with each minute having 60 seconds has its origins in ancient Greece but is based on the astronomy of the older Babylonian and Sumerian cultures. It was not until the 14th century and the advent of mechanical clocks that hours of fixed length came into general use.

Pendulum Clocks

The pendulum clock was invented by the Dutch scientist Christiaan Huygens in 1656. A mass placed at the end of a string or rod will swing back and forth in a precise time interval depending on the length of the pendulum. The 'escapement' mechanism in this clock is powered by either a spiral spring that stores energy or by a weight hanging vertically down on a cord to turn a pulley. As the pendulum swings to one side the 'escapement' pushes on an arrangement of cogs and gears that rotate the hour and minute hands by small increments. This is audible as a 'tick'. The escapement also gives the pendulum a small push to compensate for the effects of atmospheric drag. A spring must be "wound up" every few days and a hanging weight needs to be lifted back to the top of its pulley position as it reaches its lowest point. A pendulum made from a bob (mass) attached at the end of an iron rod is susceptible to the effects of thermal expansion. For this reason the position of the bob can be adjusted on the rod to adjust the effective length of the pendulum. The introduction of pendulum clocks increased accuracy from about 15 minutes per day to about 15 seconds per day.

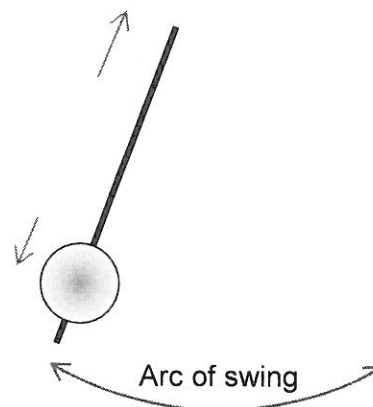
**Quartz Clocks**

If you look at your wristwatch or a wall mounted clock it is likely that you will see the word Quartz written on the face. Nowadays, timepieces using quartz technology are the most widely used in the world. A quartz clock uses an electronic oscillator regulated by a quartz crystal. The oscillator generates a very precise frequency which governs the mechanism.

Quartz (silicon dioxide) is a piezoelectric material. When it is bent it creates an electrical potential across planes in the crystal. This effect is used in reverse in a timepiece – when an electrical potential is connected across the crystal it resonates at a fixed frequency. The frequency is related to the shape, size and crystal plane of the quartz. Variations in temperature have a negligible effect on this frequency.



Quartz clocks use a quartz crystal that is a cantilever, laser trimmed into the shape of a small tuning fork and calibrated to oscillate at 32 768 Hz. This number is a power of two and is chosen so that simple digital logic circuits can derive the 1 Hz signal that indexes the second hand.

The formula for the fundamental frequency of vibration of a cantilever is as follows:

$$f = \frac{1.875^2}{2\pi} \cdot \frac{a}{l^2} \cdot \sqrt{\frac{E}{12\rho}}$$

A standard quality quartz watch will have an accuracy of around ± 15 seconds per month. A quartz watch that has been 'rated' at the factory against an atomic clock can be regulated to have an accuracy of around ± 10 seconds per year.

Atomic Clocks

The operation of an atomic clock is based on the principle of the emission of electromagnetic radiation when electrons in atoms change energy levels. Atomic clocks based on Caesium-133 have a cavity containing Cs-133 as a gas. The gas is stimulated by microwaves and controlled by an electronic amplifier which cause it to resonate and emit radiation at exactly 9 192 631 770 cycles per second. This is now the basis of the SI unit of time. Atomic clocks have an accuracy of one second per million years or better.

Questions

- a) In a pendulum clock energy is required to advance the hour and minute hands. Describe one possible source of energy that the passage refers to and briefly describe the energy transformations that occur.

(2)

- b) Would it be practical to have a wristwatch based on a pendulum mechanism? Explain briefly.

(1)

- c) A certain pendulum clock is calibrated in the winter. In summertime the pendulum will need to be adjusted to keep more accurate time. The formula for the period of a pendulum is as follows:

$$T = 2. \pi \sqrt{\frac{l}{g}}$$

- i. Explain what effect an increase in temperature would have on the accuracy of the clock. Will it run fast, slow or be unaffected? (2)
- ii. Explain what adjustment would need to be made to the position of the bob on the end of the rod to compensate for the change in temperature. (1)
- d) Is the quartz crystal in a watch behaving more like an electric generator or an electric motor? Explain briefly. (2)
- e) The frequency of a crystal oscillator in a wristwatch is 32 768 Hz. Referring to the formula in the passage, calculate the length of a quartz crystal which has a thickness of 0.3 mm, Young's Modulus of $1.00 \times 10^{11} \text{ N m}^{-2}$ and a density of 2634 kg m^{-3} . (3)

f) The number 32 768 is a power of 2. (That means that $32\,768 = 2^x$). Determine which power of 2 this is. (1)

g) Would a typical person's ear be able to hear the quartz crystal oscillating at 32 768 Hz? Explain briefly. (2)

h) Are atomic clocks based on the principle of "radioactivity"? Explain briefly. (2)

i) For the atomic clock described in the passage, calculate the difference in energy level values (joules) for the line emission referred to in the Caesium atom. (2)

End of questions

